

- General Specifications/规格:
1. Panel Size/板的尺寸: 18" x 24"(Min), 21" x 24"(Max)
 2. Panel Thickness/板的厚度: 0.05mm~3mm

TS99533-1-4 Loader Unloader

TS99533-1-4 Loader Unloader is Compact Design Handling system of PCB at tact time of about 7~8 panels per minute. It accepts slot trolleys with trays and interfaces to other processes via flat belt conveyor at pass height of about 950mm. It can be used in processes like, DFM Treatment line, Copper Plating line etc where small machine footprint is needed. Contactless centering is optional especially for Thin panels.

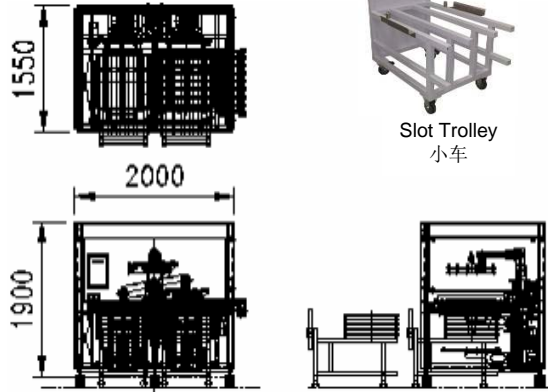

Machine

| | |
|-----------------------|-----------------------------------|
| Model | TS99533-1-4 |
| Panel Size | 18" x 24"(Min) ~ 21" x 24"(Max) |
| Panel Thickness | 0.05 ~ 3mm |
| Cycle Time | 7 ~ 8 panel/min (Max) |
| Conveyor Pass Line | 950±30mm |
| Loading Position | 2 Slot Trolley |
| Interleave | No |
| Electrical Connection | AC415V+NV, 3 phase, 50Hz, 3KW |
| Air Supply | 5 Bar, 50l/min |
| Machine Weight | 1000 Kg per unit |
| Machine Size | 2000mm(L) x 1500mm(W) x 1900mm(H) |

Options

| | |
|----------------------|---|
| Safety Feature | Swing door with safety sensor ; Sliding door with safety sensor ; Curtain sensor |
| Picker Pad | Φ33mm ; Φ20mm ; Φ18mm ; Φ14mm ; Φ12mm ; Φ10mm ; Cyclone |
| Picker Type | 2 Fixed rows and 1 Manual adjust row ; 2 Fixed rows and 3 Position pneumatic row ; 2 Fixed rows and 1 Motor adjust row ; 2 Fixed rows ; Custom design |
| Conveyor Type | Flat belt 3×30mm+2×130mm ; Flat belt 5×30mm ; Roller Φ60mm |
| PCB Stopper | Single position ; Double position |
| Separation | Single pounder ; Double pounder ; Triple pounder ; Vibration |
| PCB Edge Referencing | Diverter with hard stop ; Contactless |
| Thickness Checker | Double piece sensor |
| Identification | Ink jet printer ; vision camera |

Your Ideal Partner in Automated Engineering Equipment
 Email: transystem@pacific.net.sg